

A2

Flexible. Reliable. Efficient.

灵活 · 可靠 · 高效 ·

Design, engineering and production by one single supplier

DORNIER is the reliable partner for all requirements relating to any aspect of the production of application-specific weaving machines for manufacturing high-quality fabrics. Whether a system family consisting of rapier and air-jet weaving machines or a customized turnkey complete line: DORNIER plans, designs and builds everything in-house.

History

The world-renowned aircraft manufacturer Dornier began building textile machines after the Second World War. The reason for this change of direction: The Allied Forces had prohibited the company from building airplanes in Germany. In 1950, Lindauer DORNIER GmbH was founded in what remains the company's headquarters at Lindau-Rickenbach by Peter Dornier, son of the famous aviation pioneer Claude Dornier. The first fruits of the search for a new field of activity there were shuttle weaving machines. But soon afterwards, Lindauer DORNIER GmbH also began making specialty machines, including dryers for the cardboard, paper and construction panel industry. In the mid-1960s, film stretching lines for the packaging and plastic film industry and textile finishing machines for tubular knit goods were added to the product portfolio.

The rapier weaving machine, developed in 1967, and the air-jet weaving machine introduced in 1989 represented the most significant milestones in the company's rise to become Germany's only weaving machine manufacturer of international standing. The end products made on our weaving machines comprise extremely high-performance fabrics for airbags, carbon fabrics for composite structures and aramid fabrics for fire-resistant or bullet-proof applications. But equally for the finest silk fabrics, intricate Jacquard items and ultrafine worsteds, the DORNIER system family offers the ideal tool. In 2014 we founded the DORNIER Composite Systems® product line to continuously deliver new answers for the challenging demands of the dynamic composite industry in the form of innovative production lines for semi-finished composite products of all kinds.

由专一供应商进行设计、构建和生产

多尼尔作为可靠的合作伙伴，可提供满足各种需求的生产高质量织物的专用织机。无论是剑杆织机、喷气织机组成的织机系列还是定制的交钥匙生产线均由多尼尔自主规划、设计和构建。

历史

世界著名的飞机制造商多尼尔在第二次世界大战后开始制造纺织机械。重新定位的原因是：盟军禁止该公司在德国制造飞机。1950年著名航空先驱Claude Dornier的儿子Peter Dornier在该公司位于林道-维康巴赫的总部建立了林道尔·多尼尔有限公司。在新领域的第一个研究成果是有梭织机。不久，林道尔·多尼尔有限公司开始制造特种机械，包括纸板、纸张和建筑板材行业的干燥机。上世纪六十年代中期，多尼尔产品系列加入了用于包装和塑料薄膜工业的薄膜拉伸生产线及圆筒针织品的后整理机器。

1967年开发的剑杆织机和1989年问世的喷气织机，是多尼尔公司成为德国唯一一家具有世界知名度的织机制造商的重要里程碑。我们织机的最终产品包括用于安全气囊的极高性能织物、用于复合结构的碳纤维织物以及用于防火或防弹应用的芳纶织物。同样最好的丝绸面料，精致的提花织物和超细精纺毛料，多尼尔系列织机都是不二之选。2014年，我们推出获得专利的多尼尔复合材料生产线，以各种半成品复合材料产品的创新生产线的形式，不断为动态变化中的复合材料行业的挑战性需求提供新的解决方案。



INNOVATIVE BY TRADITION

人间正道是沧桑： 传统与创新

“Made in Germany”

Weaving machines by DORNIER are “Made in Germany”. A high production depth demonstrates the strength of the company’s in-house value creation. It enables us to offer our customers the highest possible quality, durability and flexibility for efficient, process- reliable and scalable manufacturing of fabrics.

“德国制造”

多尼尔织机是“德国制造”。深厚的制造业底蕴展示了公司内部价值创造的实力。它保证了我们能够为客户提供高质量、耐用、高效灵活、工艺可靠和可扩展的织物制造。



Quality creates value: individual serial production

No two machines are exactly alike; each one is designed, developed and built specifically for its intended purpose in close consultation with the customer. Even so, all machines have something in common: high economy, quality and reliability are standard.

质量创造价值：个性化批量生产

没有两台机器是完全相同的，每一台都是在与客户密切沟通协商的基础上专门为其预期目的而设计、开发和制造的。即便如此，所有机器都有一个共同点：高经济性、高质量和可靠性是标准配置。



THE DORNIER SYSTEM FAMILY: RAPIER AND AIR-JET WEAVING MACHINES

多尼尔织机系列: 剑杆织机和喷气织机

Outstanding range of application

The DORNIER system family consisting of rapier and air-jet weaving machines is based on an exceptionally robust machine frame and equipped with standardized electronics. So operating and maintenance personnel work on standardized machine structures despite differing insertion systems. The structural modular principle reduces component variation and maintenance effort. Accessories and spare parts are largely interchangeable, saving money and minimizing storage requirements.

适用范围广

多尼尔织机系列由剑杆织机和喷气织机组成，基于非常坚固的机架，并配备了标准化的电子设备。因此，尽管引纬系统不同，但操作和维护人员仍在标准化的机器结构上工作。结构模块化原理减少了组件变化和维护的工作量。辅件和备件在很大程度上是可互换使用，从而节省了资金并最大限度地减少了库存。

Identical elements for all machines:

- DORNIER ErgoWeave® Dialog Panel
- FT control and drive concept
- Electronical components for main control
- Selvage formation device
- Access to customer portal myDoX®
- Connectivity
- Electronic Warp Let-off (EWL)
- Electronic Cloth Take-up (ECT)

适用于所有机器的相同元件:

- 多尼尔 ErgoWeave® 对话框
- FT 控制和驱动概念
- 用于主控的电子元件
- 布边装置
- 访问多尼尔客户门户网站myDoX®
- 联接
- 电子送经装置 (EWL)
- 电子卷取装置 (ECT)

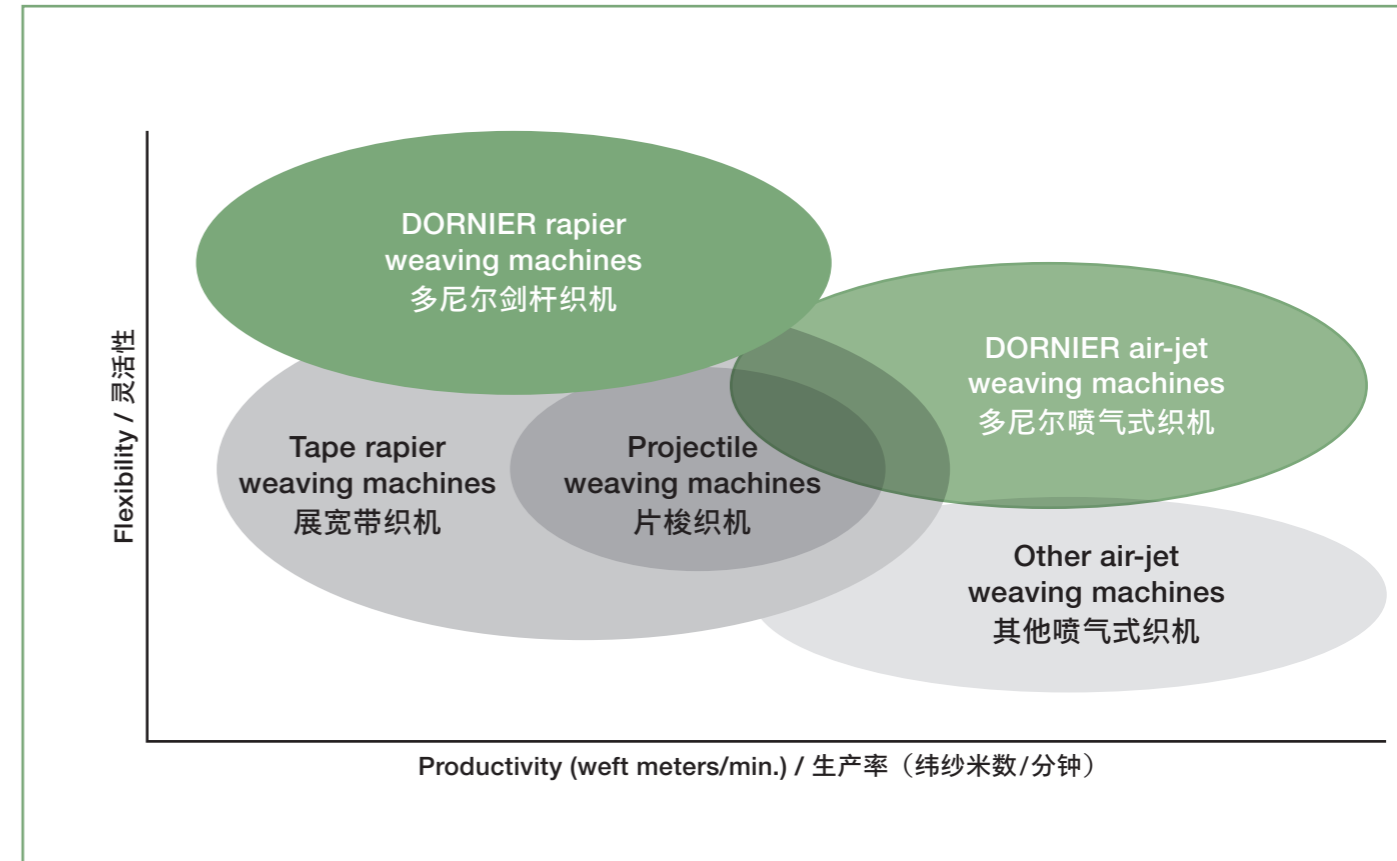

A standard for productivity and flexibility

The high production speed of the DORNIER weaving machines with consistent end-to-end process reliability ensures maximum productivity. Due to their exceptional flexibility, the machines can efficiently manufacture large and small product batches from safety textiles to wool – a competitive advantage for the customer.

生产率和灵活性的标准

多尼尔织机高效的生产速度和一致的工艺可靠性确保了最大的生产率。由于其卓越的灵活性，这些机器可以有效地生产从安全用纺织品到羊毛织物等大批量或小批量多品种产品，这是客户的竞争优势。



FUTURE-ORIENTED CUSTOMIZED SOLUTIONS: DORNIER A2 AIR-JET WEAVING MACHINE

面向未来的定制解决方案： 多尼尔A2喷气织机

DORNIER Air-Jet weaving machine A2 – productivity with highest quality

In contrast to rapier weaving machines, air-jet weaving machines transport the filling thread without mechanical elements. Rather, an air stream shoots the transverse weft threads from one selvedge to the other at top speeds of up to 300 km/h to interlace them with the warp threads. At the end of this process there is the woven fabric.

The DORNIER air-jet weaving machine A2 – a real all-round talent – offers innovative solutions for all challenges of weaving, today and tomorrow. Built on the proven technology of the DORNIER system family, the A2 convinces with a future-proof control and powerful concepts.

Whether operating with a simple cam motion, in combination with a Jacquard head with a high number of hooks, a dobby machine or with the DORNIER EasyLeno® motion – the A2 is the perfect tool for the creative, economical and precise production of technical fabrics, home textiles and garment fabrics. It is available in machine widths ranging from 150 up to 540 cm. A multitude of patented components such as DORNIER PIC System, DORNIER ServoControl®-2 or DORNIER PneumaTucker® guarantee a process security which is unparalleled in air-jet weaving. Latest technologies such as DORNIER EcoValveControl®+ and Electronic Pressure Monitoring (EPM) ensure highest energy efficiency.

The application spectrum of the A2 ranges from technical textiles such as lightest spinnaker silk, tightly woven airbags or conveyer belting to car and airline seating Jacquard upholstery. Fabrics for garments fine worsted of Jacquard damast fabric, function and sportswear fabrics, home textiles for decoration and Jacquard table cloth with matching napkins in multiple widths, sheer window drapery – all these goods and many more can be reliably produced on the A2 with excellent quality.

多尼尔喷气织机A2- 生产效率最高， 织物质量最好

与剑杆织机相比，喷气织机无需机械部件即可引纬。另外，气流以高达300公里/小时的速度将纬纱从一侧引到另一侧，将它们与经纱交织在一起。在这个过程完成后生产出机织物。

多尼尔喷气织机A2- 真正的全能织机-为当今和未来的所有织造挑战提供创新的解决方案。A2建立在多尼尔系列的成熟技术之上，以永不过时的控制和强有力的概念令人信服。

不管是配以简单的凸轮装置，大针数的提花机，多臂机还是多尼尔EasyLeno®简易纱罗装置-A2喷气织机都是以最佳和最经济手段生产创新和要求精细的产业用布，家纺织物和服装面料的最佳选择。机器标称幅宽从150厘米到540厘米。众多专利组件，如多尼尔PIC实时引纬控制系统，多尼尔SeverControl®-2伺服控制系统或多尼尔PneumaTucker®气动折入边系统保证了多尼尔喷气织机生产织造的安全性，令其它织机望尘莫及。最新技术，如多尼尔EcoValveControl®+和电子压力监测（EPM）确保最高的能源效率。

A2在织造产业用布方面应用广泛，可以织造产业用布，薄纱、紧实的安全气囊和传输带，以及汽车和飞机的座椅装饰布。服装用的提花贡缎精纺毛料，功能性面料和运动类面料，以及装饰用家纺织物，与餐巾配套的不同幅宽的桌布，窗帘布，所有这些织物都可以在A2上可靠生产，且质量上乘。



The A2 at a glance

- Sturdy machine frame and solid reed drive system
- Low-maintenance main drive systems
- Reproducible setting of shed closing time with DORNIER SyncroDrive®
- Fast symmetrical and asymmetrical width changes
- Latest valve technology for fast reaction times and high process reliability
- High-performance nozzles and electronic support systems to reduce air consumption
- Automatic Filling Repair (AFR) for high operating efficiency

A2 概览

- 牢固的机架和稳定的钢箔驱动系统
- 低维护主驱动系统
- 使用多尼尔SyncroDrive®同步驱动可重复设置梭口闭口时间
- 梭口闭口时间
- 快速的对称和非对称宽度调节
- 最新的喷气阀门技术，反应时间快，工艺可靠性高
- 高性能喷嘴和电子支持系统，减少压缩空气消耗
- 自动纬纱修复（AFR），生产效率高

ROBUST TECHNOLOGY, INTELLIGENT DESIGN: THE A2

强大的技术, 智能的设计: A2

Intuitive operation and networked production

直观的操作和
网络化生产

24 | 25

Precise and stable: from the center of the machine

精确且稳定:
从机器的中心开始

12 | 13

Efficient, reliable and flexible: aktive filling insertion

高效、可靠、灵活:
主动的引纬系统

14 | 15

High application diversity: the shedding geometry of the A2

应用广泛:
A2的梭口形状

18 | 19

Controlled and gentle: warp and fabric movement

可控且处理轻柔:
经纱和织物运动

22 | 23

A seal of quality: the selvedge

可靠质量的保证: 边组织

20 | 21

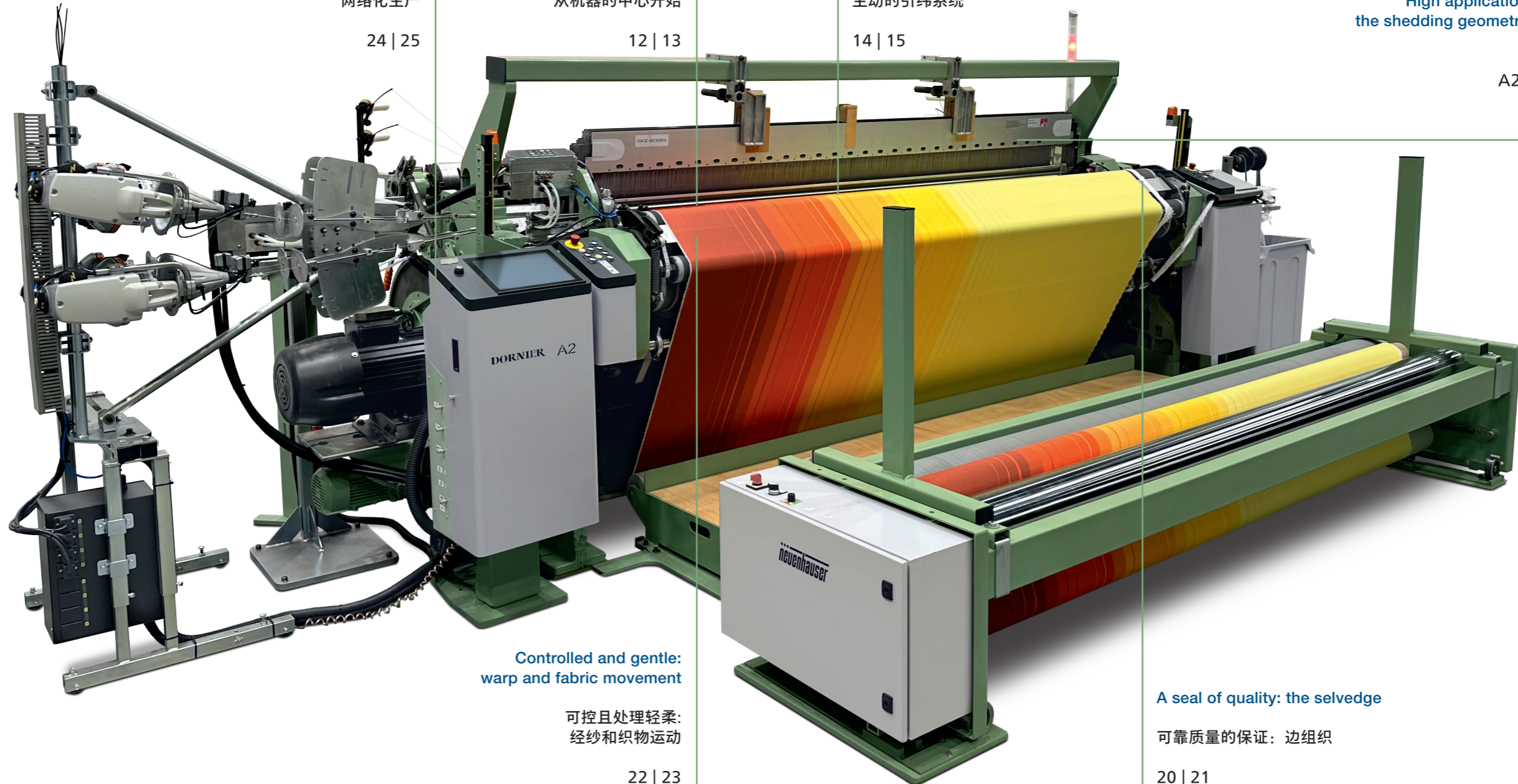

Direct Link: Industry 4.0 / 直接链接: 工业4.0

Fast-Ethernet-Technology / 快速以太网技术

PRECISE AND STURDY: THE MACHINE CENTER

Modular base concept: Sturdy construction and precise reed movement

Reliability in the production of high-value fabrics starts with a sturdy machine frame, equipped with a solid reed drive system. The mass-reduced but extremely stable reed bar guarantees an exact and well-balanced reed beat-up. The vibration behaviour is significantly improved and start marks are practically eliminated.

The main gearbox: Safety through precision

The bilateral reed drive of the A2 is equipped with a main shaft rotating at accelerated speed, which connects the two gearboxes. Combined with a drive train section, it forms an exceptionally sturdy unit. The two high-precision synchronously running gearboxes, produced in-house, are positioned at both sides of the machine. Even at highest speeds, they guarantee an optimal dynamic behaviour. The central lubrication unit combines highest performance with low maintenance and ensures a long service life of the gearboxes.

模块化框架结构概念：坚固的结构和精确的钢筘运动

牢固的机架，稳定的钢筘驱动系统，从一开始就保证了高级织物安全可靠的生产织造。简单而又坚固的筘座，确保打纬均匀且精确，织机震动减至最低，最大限度消除了开车痕。

主齿轮箱：精确以保证安全性

2配备主传动轴连接两个齿轮箱，进行加速旋转，双向驱动钢筘。结合传动序列，装置结构牢固。两个多尼尔公司自主生产的高精度同步运行的齿轮箱位于机器的两侧。即使在最高速度下，它们也能保证最佳的动态性能。中央润滑系统将最高性能与低维护相结合，并确保齿轮箱的使用寿命。

精确且牢固： 从机器的中心开始

High-performance, durable and low-maintenance: The DORNIER main drives

Minimal speed variations and simple operation: The durable DORNIER main drives rely on leading edge technology to deliver ideal production conditions and maximum insertion performance. Automatic Start Mark Prevention (ASP) guarantees optimum start-stop behavior.

The patented DORNIER SyncroDrive® with intelligent control allows extremely low speed fluctuations even with high numbers of shafts and for large-size Jacquard machines. Shed closing timing is electronically adjustable during machine run and is stored with the article data. DORNIER SyncroDrive® thus enables reproducible production and supports intuitive production parameter optimization. DORNIER DirectDrive is the ideal main drive concept for high-performance air-jet weaving machines with cam motion or DORNIER EasyLeno®.

高性能、耐用、低维护：多尼尔主驱动

最小的速度偏差和简单的操作：多尼尔耐用的主驱动依靠领先的技术提供理想的生产条件和最大的输送性能。自动防开车痕（ASP）可确保最佳的开车-停车性能。

获得专利的多尼尔SyncroDrive®同步驱动具有智能控制功能，即使在综框数量多或配备大针数提花机时，也能实现极低的速度波动。在机器运行期间梭口闭合时间可通过电子方式调节，并与织物数据一起存储。因此，多尼尔 SyncroDrive®同步驱动可实现重复的生产，并支持直观的生产参数优化。多尼尔DirectDrive直接驱动是高性能喷气织机在配备凸轮装置或多尼尔EasyLeno®简易纱罗装置时最理想的主驱动。

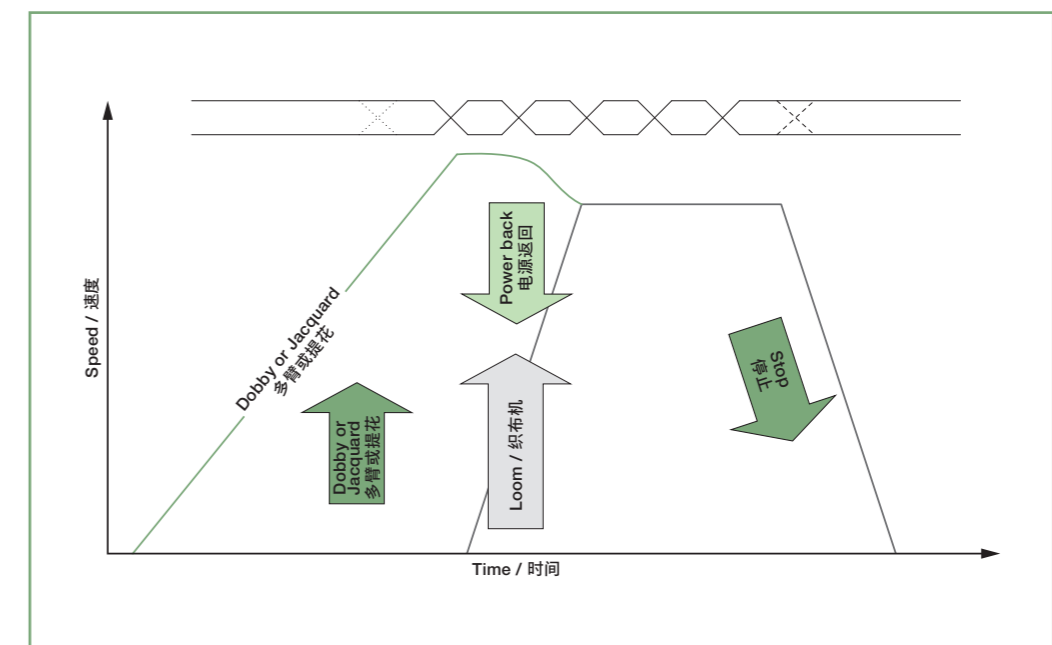

EFFICIENT, RELIABLE AND FLEXIBLE: ACTIVE FILLING INSERTION

高效、可靠且灵活： 主动引纬系统

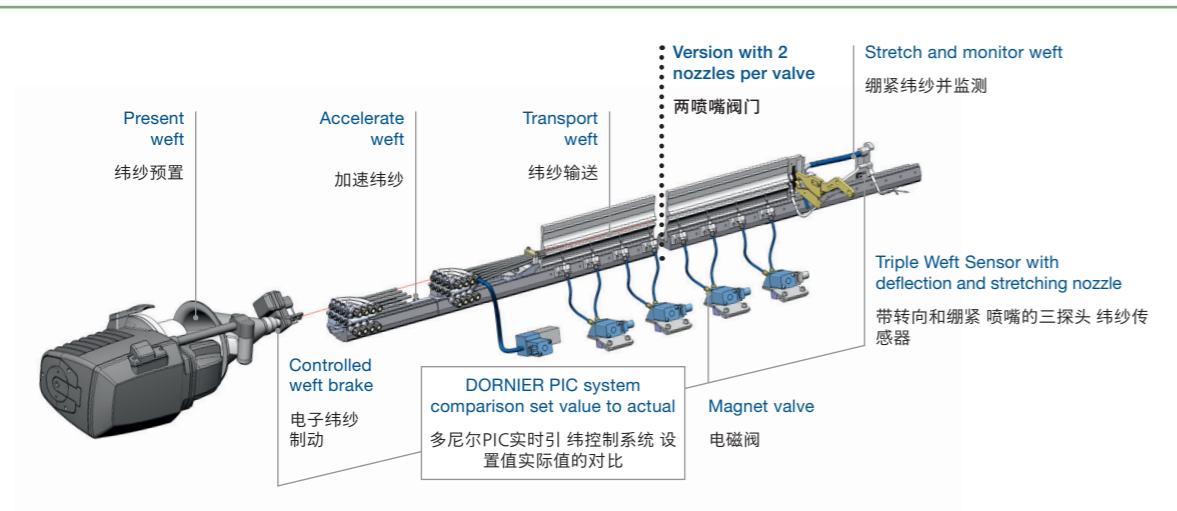

Highest process reliability: Permanent Insertion Control (PIC)

DORNIER Permanent Insertion Control (PIC) continuously monitors all weft insertion elements. When exceeding defined tolerance limits, the operator is instantly informed and the machine can be stopped on request. This unique control of the weft filling insertion process guarantees highest process reliability while maintaining superior fabric quality and avoiding maintenance stops.

Consistent fabric quality: DORNIER ServoControl®-2

The patented DORNIER ServoControl®-2 system continuously adjusts the air pressure of main and pre-nozzles on the left-hand side of the machine in order to precisely maintain the target filling yarn arrival time on the right-hand side. The intelligent algorithm calculates the required pressure values pic-à-pic for up to eight weft colours. The pressure values are stored with the article data and are conveniently displayed on the DORNIER ErgoWeave® panel. With its high degree of automation and intuitive reproducibility of article data, DORNIER ServoControl®-2 enables the operator to achieve the highest possible fabric quality.

最高的工艺稳定性：实时引纬控制系统（PIC）

多尼尔实时引纬控制系统（PIC）持续监控所有引纬元件。当超过定义的公差限值时，挡车工会立即收到信息，并可根据要求停止机器运行。这种对引纬过程的独特控制保证了最高的工艺稳定性，确保了织物的高品质织造，并减少不必要的养护停车。

始终如一的织物质量：多尼尔ServoControl®-2伺服控制系统

获得专利的多尼尔ServoControl®-2伺服控制系统能连续调节机器左侧主喷嘴和预喷嘴的空气压力，以精确保持引入纬纱到达机器右侧的时间。智能算法可计算多达八种纬纱中每种纬纱的空气压力值。压力值与织物数据一起存储，并方便地显示在多尼尔ErgoWeave®面板上。凭借其高度自动化和织物数据的直观可重复性，多尼尔ServoControl®-2伺服控制系统协助挡车工尽可能织造高质量的织物。

Low air consumption through innovative valve control

DORNIER EcoValveControl® (EVC) automatically detects the arrival of the filling yarn at the relay nozzles. The system only activates the solenoid valves when the tip of the filling yarn has actually arrived at the respective relay nozzle. This high-precision activation process ensures an optimal filling insertion and reduces air consumption. With DORNIER EcoValveControl®+ (EVC+) the individual switching behaviour of each valve is taken into account. This additionally reduces air consumption and increases the possible valve service life.

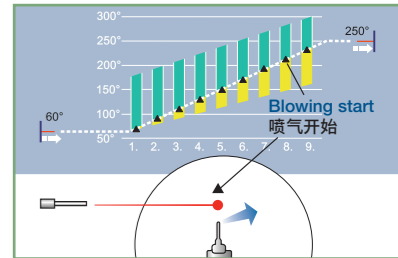

Optimized main air supply

The Electronic Pressure Monitoring (EPM) continuously measures the pressure and flow rate of main air supply. In addition, the Electronic Pressure Regulation (EPR) allows reproducible settings and access control for the adjustment of the pressure levels of both relay nozzle air tanks and stretching nozzle as well as tuck-in device. This increases the reproducibility of settings in the weaving shop floor and is the basis for further measures to reduce air consumption in the weaving mill.

Increased operating efficiency: Intuitive control and automatic processes

Several support systems are designed to assist the operating personnel in the weaving process. Automatic Package Switching (APS) and Automatic Package Monitoring (APM) increase efficiency in the weaving mill. The Start Weaving Assistant (SWA) significantly facilitates optimization of machine parameters for new articles. The Automatic Filling Repair (AFR) reduces machine downtime and thus is crucial in further increasing operating efficiency.

通过创新的阀门控制降低压缩空气消耗量

多尼尔EcoValveControl® (EVC) 节气装置可自动检测到辅助喷嘴的纬纱。只有当纬纱头部实际到达相应的辅助喷嘴时，系统才会激活电磁阀。这种高精度的激活过程确保了最佳的引纬并减少了压缩空气的消耗。使用多尼尔EcoValveControl®+ (EVC+) 节气装置能独立开闭每个阀门。这进一步减少了压缩空气的消耗并延长了阀门的使用寿命。

优化压缩空气的供给

压缩空气电子压力监测（EPM）连续测量进口空气压力和流量。此外，电子压力调节（EPR）允许可重现的设置，以便调整两个辅助喷嘴气包，拉伸喷嘴和折入边装置的压力值。这增加了织造中设置的可重现性，从而进一步减少了织造厂压缩空气的消耗量。

提高运行效率：直观的控制和自动化过程

设计有几个支持系统来协助挡车工进行织造过程。自动纬纱筒子切换（APS）和自动接头监控（APM）可提高织造厂的效率。启动织造助手（SWA）有助于优化新织物的机器参数。自动纬纱修复（AFR）减少了机器停机时间，因此对于进一步提高运行效率至关重要。

UNIQUE: THE ELEMENTS OF FILLING INSERTION

独特性： 引纬元件

Precise acceleration: Pre- and main nozzles

The pre- and main nozzles of the A2 accelerate the filling yarn with high efficiency. Their configuration can be customized to account for a large range of yarn types. Combinations of one mobile main nozzle with one stationary pre-nozzle (HD+) or with two stationary pre-nozzles (HD++) are ideal for highest machine speeds. The configuration with two mobile nozzles (TDM) offers an economic solution for a wide of applications. In combination with an additional stationary nozzle (TDM+) the weft insertion performance is further increased. For wide machines, three mobile nozzles (TRIM) enable an efficient production.

Secure filling transport: relay nozzles

The strength of the DORNIER single-hole relay nozzle is its uncomplicated usage, free of any maintenance procedures. The conicity of the air hole opening creates an optimal air flow. The nozzle's hardened surface is gentle to the thread and ensures the durability DORNIER is known for. A pair of two relay nozzles is activated by one highly dynamic and precisely controlled solenoid valve.

Process monitoring: Triple Weft Sensor (TWS)

The and conceptually modular Triple Weft Sensor (TWS) consists of a first and second filling stop motion combined with a stretching nozzle. It guarantees precise filling control of even most delicate yarns. The first filling stop motion monitors thread arrival, the second one detects thread breaks during insertion. The distance between both filling stop motions can be adjusted in accordance with filling yarn elasticity. After read beat-up, the thread is taken up by the deflection nozzle, so that the stretching nozzle remains always free for the next filling insertion.

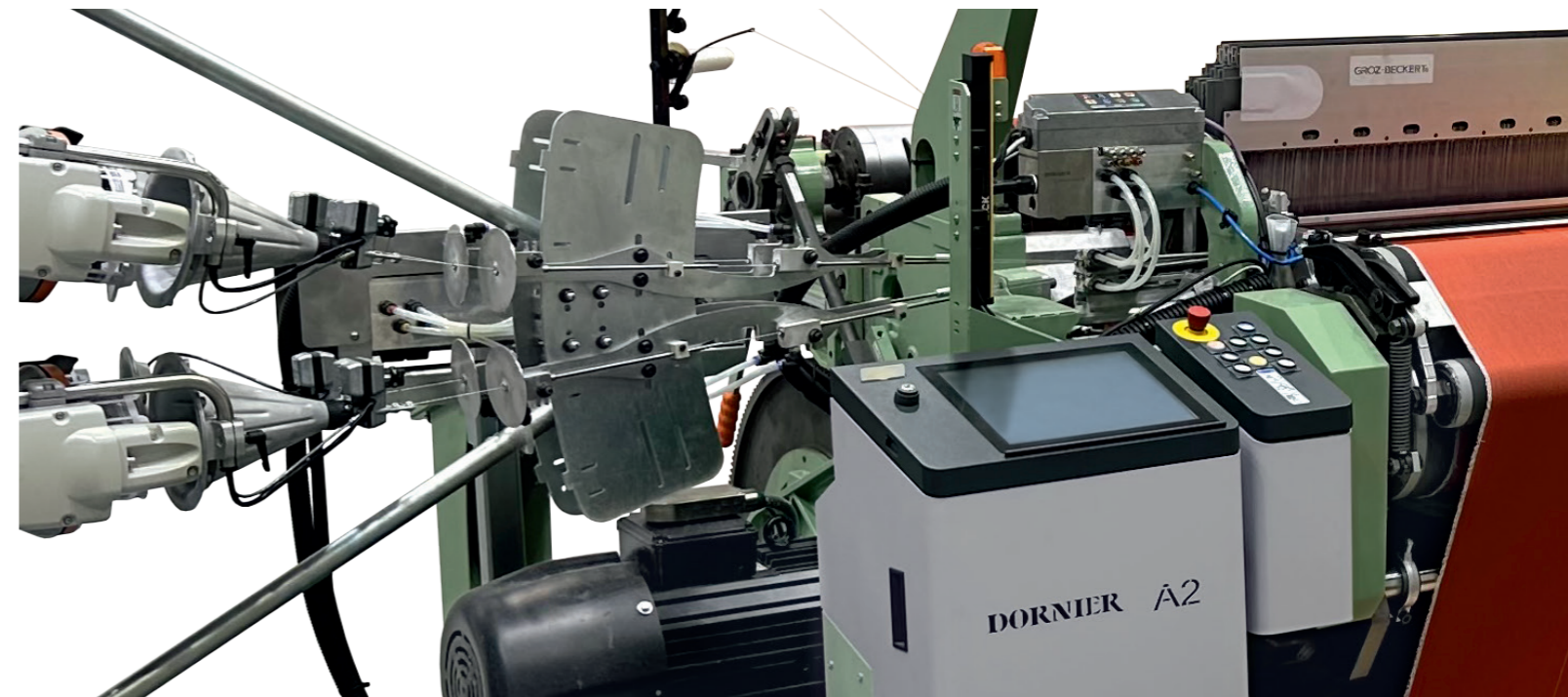

精确加速：预喷嘴和主喷嘴

A2的预喷嘴和主喷嘴以高效率加速引纬。它们的配置可以定制，以适应多种类型的纱线。一个移动式主喷嘴与一个固定式预喷嘴（HD+）或两个固定式预喷嘴（HD++）的组合是实现最高机器速度的理想选择。带有两个移动喷嘴（TDM）的配置为广泛的应用提供了经济的解决方案。结合额外的固定喷嘴（TDM+），引纬性能能进一步提高。对于宽幅机器，三个移动喷嘴（TRIM）可实现高效生产。

安全的纬纱输送：辅助喷嘴

多尼尔单孔辅助喷嘴的优势在于其使用简单，无需养护。带锥度的气孔开口能产生最佳气流。表面经硬化的喷嘴能轻柔地处理纬纱，使用寿命更长。每两个辅助喷嘴受控于一个高动态和精确控制的电磁阀。

引纬监控：三探头纬纱传感器（TWS）

模组式三探头纬纱传感器（TWS）由第一道和第二道纬停装置以及拉伸喷嘴组成。即使是对最细的纱线，它可以进行精确的引纬控制。第一道纬停装置检测纱线的到达时间，第二道纬停装置检测引纬过程中的断纬情况。两道纬停装置间的距离可以根据纱线的弹性进行调整。打纬后，纱线有转向喷嘴握持，而拉伸喷嘴处于无纱状态下，为下一次引纬做好准备。



WIDE RANGE OF APPLICATIONS: SHEDDING OF A2

织造范围广泛: A2织机的梭口

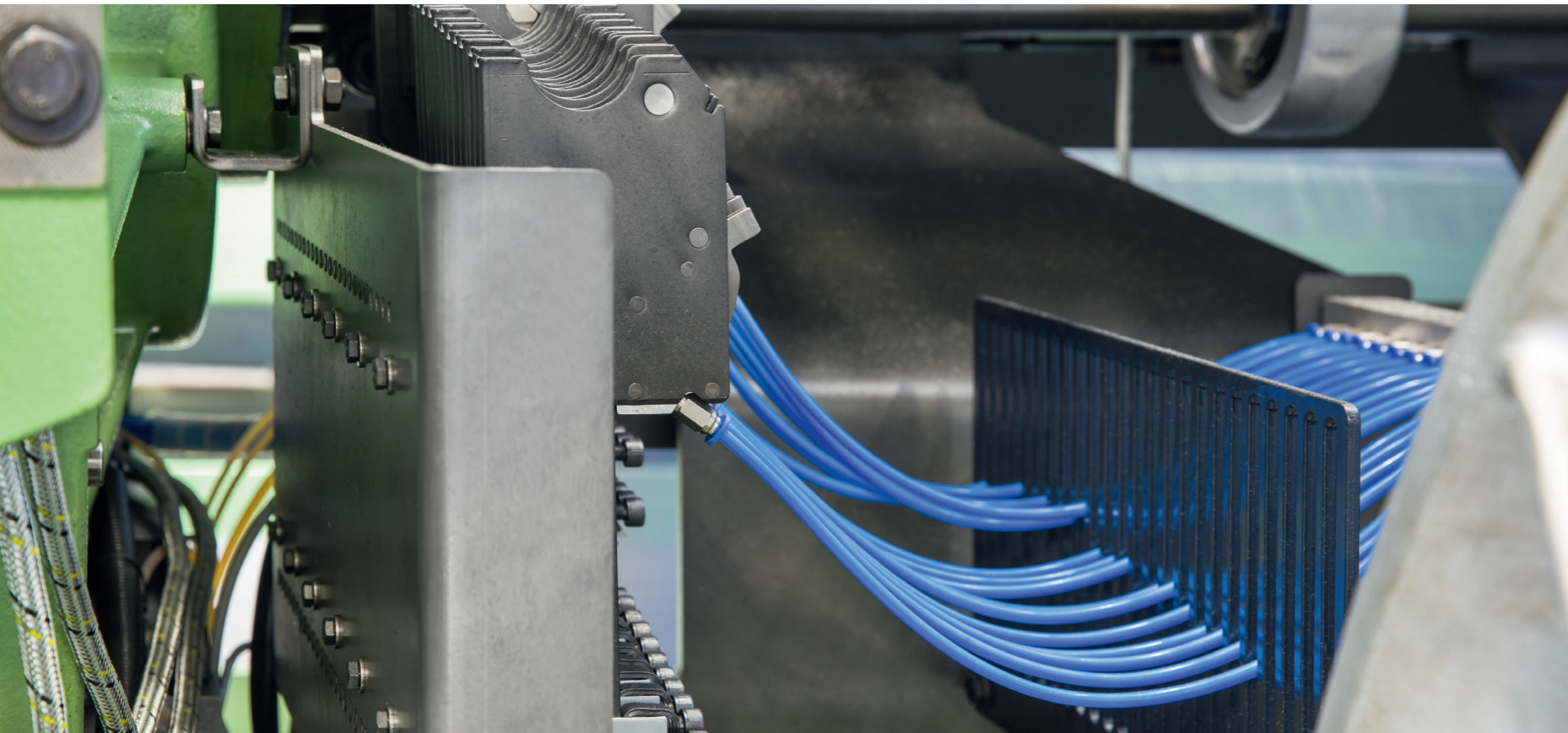

At the center of the weaving process: The A2 shed geometry

The ideal arrangement of all shedding and weft insertion elements enables the operator to optimize shed geometry for an ideal filling insertion window. This guarantees safe and efficient processing of a wide range of weft and warp materials.

Sturdy and low-maintenance shaft drive

DORNIER AutoLub automatic circulating lubrication guarantees a long service life for the undermotion elements, even under heavy loads. Pneumatic Shaft Lock (PSL) considerably reduces setup time at article changes.

织造工艺的核心：A2织机的梭口几何形状

所有开口和引纬部件的理想布置使挡车工能够优化梭口几何形状，以获得理想的引纬窗口。这保证了各种纬纱和经纱材料的安全和高效织造。

牢固且低维护的轴驱动

多尼尔AutoLub自动循环润滑保证了综框的下传动装置的使用寿命，即使在重载下也是如此。气动综框锁紧系统（PSL）大大减少了更换织物品种时的设置时间。

Shedding devices for a wide range of applications

For weaving with shafts, the A2 is available with electronic dobby or cam motion. In addition, it is compatible with DORNIER EasyLeno® for manufacturing leno fabrics and with Jacquard machines for producing highly complex weave patterns.

适用于各种织物的开口装置

对于带综框的织造，A2可配备电子多臂或凸轮开口机构。此外，它可与多尼尔EasyLeno®简易纱罗兼容，用于织造纱罗织物。若与提花机配合，用于织造高度复杂的织物图案。

A SEAL OF QUALITY: THE SELVEDGE

DORNIER MotoLeno® and DORNIER MotoEco

DORNIER MotoLeno® can handle different filling densities and fabric constructions. It considerably reduces warp end breaks in the selvedge zone and forms a stable frame for subsequent finishing. As an alternative, the modularly designed and DORNIER MotoEco double-disk leno is available. It ensures an intensive binding with very short yarn ends, thus reducing waste. No additional shafts are required for selvedge and catch selvedge.

多尼尔MotoLeno®和多尼尔MotoEco

多尼尔MotoLeno®适用于各种纬密和组织结构的织物。布边的经纱断头大大减少，并为后道织物整理形成稳定的结构。作为替代方案，可以使用模块化设计的多尼尔MotoEco双圆盘绞边装置。它能够紧锁短小的纱头，从而减少浪费。无需额外的综框用于布边和废边。

可靠质量的保证： 边组织



Economic tuck-in selvages: DORNIER PneumaTucker®

The pneumatic tuck-in device DORNIER PneumaTucker® tucks in the thread end by an electronically controlled short jet of air. Tuck-in depth, number of simultaneously to be tucked-in filling ends as well as timing for the electronically controlled scissors are adjustable via DORNIER ErgoWeave® panel. The advantages are reduced changeover time when weaving multiple fabric widths, reliable functioning without mechanically driven parts and consistent selvedge quality even at highest machine speeds. The tuck-in selvedge unit is also available as center tuck-in device for multiple-width fabric weaving.

折入边装置：多尼尔PneumaTucker®气动折入边装置

多尼尔PneumaTucker®气动折入边装置通过电子控制的气流将纱头折入布边。折入深度、折入的纱线根数和电子控制的废边剪刀的剪切时间均可通过多尼尔ErgoWeave®触摸屏来设定。优点：在多幅织造时的切换时间缩短，无需机械驱动部件即可可靠运行，即使在最高机器速度下也能始终如一地保持布边质量。多幅织造时折入边装置也可用作中央折入装置。



GENTLE CONTROL: WARP AND FABRIC MOVEMENT

轻柔的控制： 经纱和织物运动

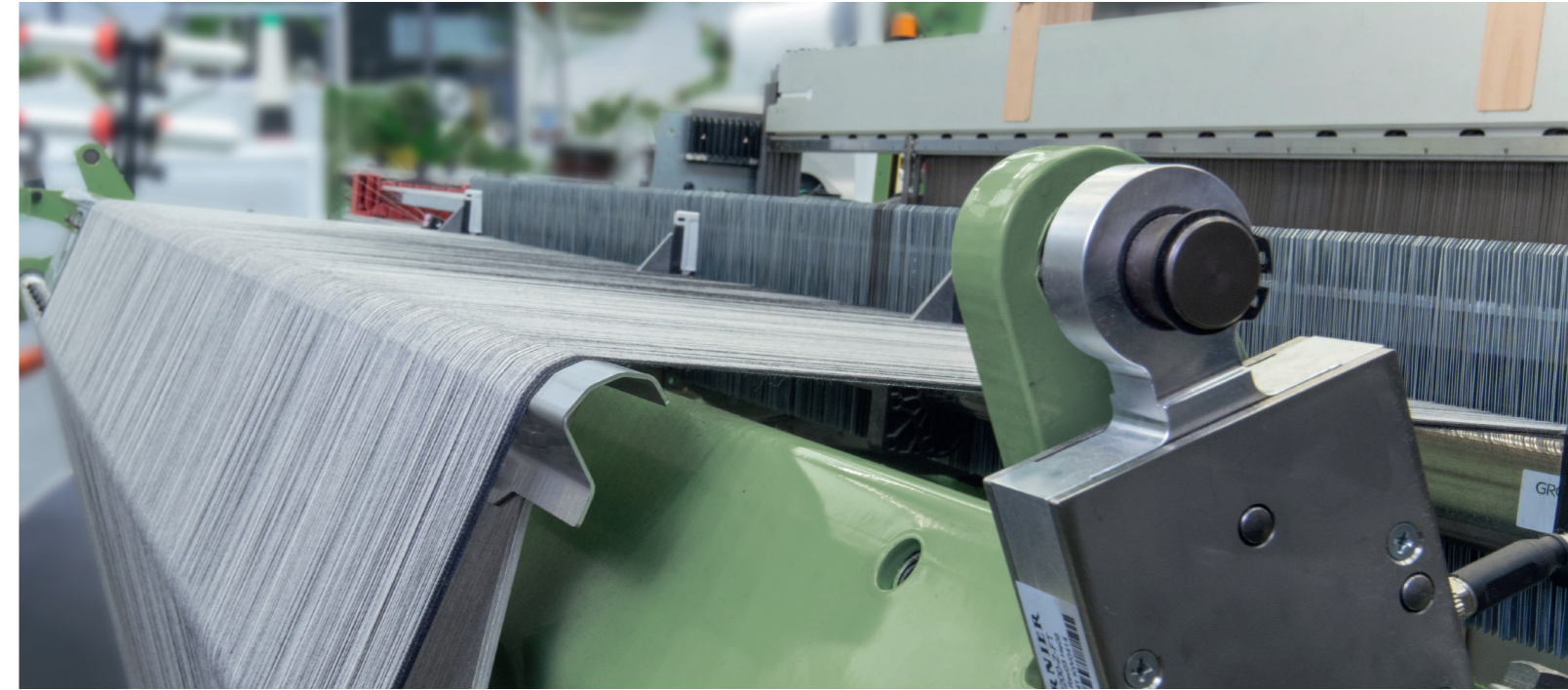

Full tension control from warp to cloth

A holistic control concept enables precise control over tension conditions from warp to cloth. The Electronic Warp Let-off (EWL) uses warp tension sensors to realize closed-loop control of the warp tension. At the same time, the electronically controlled Electronic Cloth Take-up (ECT) ensures that the set target filling density is precisely met. Therefore, even the most demanding fabrics can be manufactured with consistent quality.

Ideal compensation: Back-rest roller systems

The requirements for the back-rest roller system vary considerably depending on the application and the warp material. With various solutions from spring-mounted to mechanically controlled back-rest rollers, DORNIER comprehensively meets these requirements. With DORNIER DynamicWarpGuide (DWG), a highly dynamic, lightweight system for cost-effective production of sensitive fabrics is available.

从经纱到织物的张力控制

整体控制概念可以精确控制从经纱到织物的张力条件。电子送经装置（EWL）使用经线张力传感器实现经纱张力的闭环控制。同时，电子控制的电子卷取装置（ECT）确保精确满足设定的目标纬纱密度。因此，即使要求最高的织物也可以以一致的质量进行织造。

理想的经纱张力补偿：后梁罗拉系统

后梁罗拉系统的要求因织物品种和经纱材料而异。通过从弹簧加载张力传感器到机械驱动、电子控制的后梁罗拉等各种解决方案，多尼尔全面满足了这些要求。使用多尼尔DynamicWarpGuide（DWG）动态后梁，轻质且能实时补偿经纱张力，用于经济高效地生产对张力波动敏感的织物。

Versatile options: Warp yarn feed

DORNIER offers the EuroFix warp beam bearing for top and ground warp as well as for split warp beams. With additional external warp beam stands the application spectrum is further broadened. For weaving from creel, a positively controlled feed roller and a set of guiding rollers are integrated. In addition, an auxiliary reed ensures that all warp ends run parallel.

多种选择：经纱喂入

多尼尔提供用于上经轴和地经轴以及并列双经轴的EuroFix经轴支座。也可通过增加外部经轴支架，织造范围得到进一步拓宽。对于从纱架引经织造，集成了一个积极控制的喂入辊和一组导向辊。此外，辅助钢筘可确保所有经线平行喂入。

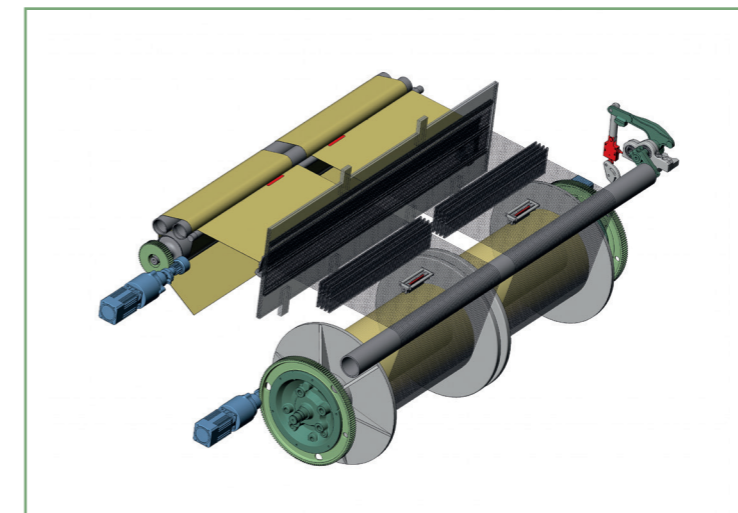

INTUITIVE INTERFACE AND NETWORKED PRODUCTION

直观的界面和网络化生产

Intuitive control: The advantages of DORNIER ErgoWeave®

- Touchscreen panel with structured user interface
- Operator support for safe and efficient fabric production and machine maintenance
- Personalized and secure access
- Style data storage for rapid style changes and high reproducibility
- Online documentation and spare parts catalog access
- Machine connectivity, remote maintenance and online backups with DoXWeave/DoXNet

Highly performant and ready for industry 4.0: DORNIER Fast-Ethernet-Technology (FT)

The entire communication of control, process and production management levels takes place through a Fast-Ethernet-Technology bus adapted specifically for DORNIER weaving machines. The fact that the system is also used to guarantee safety in modern aircraft is evidence that DORNIER is highly committed to the secure transfer of data in real time.

直观的控制：多尼尔ErgoWeave®的优势

- 结构化用户界面的触摸屏面板
- 支持挡车工安全高效的织物生产和机器维护
- 个性化和安全的访问
- 织物工艺数据存储，可实现工艺的快速更改和高度的重现性
- 在线文档和备件目录访问
- 通过DoXWeave/DoXNet进行机器连接、远程维护和在线备份

高性能以及为工业4.0做好准备：多尼尔快速以太网技术（FT）

通过以太网，可以对多尼尔织机的整个控制、工艺和生产管理进行人机交流。该系统还用于保证现代飞机的安全，这一事实证明了多尼尔高度致力于实时安全传输数据。



DORNIER DoXNet: Networked production

DORNIER DoXNet connects weaving machines in one or more weaving shop floors to form a machine network. The software provides the user with a simple overview of the current status of all connected weaving machines via a browser-based dashboard. DoXNet runs on the company's in-house network infrastructure and does not require internet access. In this way, the customer remains in complete control over his data, including sensitive production details.

DORNIER DoXWeave: Central management of DORNIER weaving machine data

DORNIER DoXWeave is a PC program for managing, reading and creating data of DORNIER weaving machines. Together with DoXNet, it enables the exchange of data between DORNIER weaving machines and DoXWeave via the internal company network and without using any physical data carriers. The combination of DoXWeave and DoXNet also enables remote access to connected weaving machines.

多尼尔DoXNet：网络化生产

多尼尔DoXNet将一个或多个织造车间的织机连接起来，形成一个机器网络。该软件通过基于浏览器的显示屏为用户提供所有连接的织机当前状态的简单概览。DoXNet在公司内部的网络基础设施上运行，不需要互联网接入。通过这种方式，客户可以完全控制其数据，包括敏感的生产细节。

多尼尔DoXWeave：多尼尔织机数据的集中管理

多尼尔 DoXWeave是一个PC程序，用于管理，读取和创建多尼尔织机的数据。与DoXNet一起，它可以通过公司内部网络在多尼尔织机和DoXWeave之间交换数据，而无需使用任何物理数据载体。DoXWeave和DoXNet的结合还可以远程访问连接的织机。

SERVICE FOR YOUR SUCCESS: DORNIER SERVICE ADDS VALUE®

为您的成功服务：
服务提升价值

Close to the customer all over the world

You can contact the DORNIER customer service staff not only at the Service Center in Lindau, but also in all major market territories for systems and machines. In the US, India, China and Turkey, DORNIER also operates its own subsidiaries. The service staff can assist you in German, English, French, Spanish, Italian, Russian, Chinese, Hindi, Portuguese Romanian and Turkish.

Inspections, upgrades and conversion sets

Whatever you weave, it is most important to DORNIER that you maintain and advance your performance capability to the maximum degree possible. Whether inspections of machine efficiency, custom conversions or the very latest upgrades for older machine generations: DORNIER will continue to meet the high quality requirements of its customers long after the purchase is complete.

Training and training courses: With us or on-site?

Have you bought a weaving machine or hired new personnel who are not familiar with the weaving machines from DORNIER? At our modern Training Centers in Lindau, Charlotte, Mumbai and Shanghai, but also in your local weaving mill, experienced trainers will turn your employees into specialists in efficient weaving

贴近全球客户

您不仅可以联系我们位于林道的服务中心的客户服务人员，还可以联系我们机器所在的所有主要市场。在美国，印度，中国和土耳其，多尼尔还有自己的子公司。服务人员可以用德语、英语、法语、西班牙语、意大利语、俄语、中文、印度语、葡萄牙语，罗马尼亚语和土耳其语为您提供帮助。

检查、升级和转换件

无论您织造什么，对多尼尔来说最重要的是最大限度地保持和提高您织机的性能。无论是检查机器效率，定制转换还是旧机器的最新升级：多尼尔将在购买完成后继续满足客户的高质量要求。

培训和培训课程：在多尼尔培训中心还是在客户现场？

您是否购买了织机或雇用了不熟悉多尼尔织机的新员工？在林道、夏洛特、孟买和上海的现代化培训中心，或者客户自己的工厂，经验丰富的培训师将把您的员工培养成高效的织造专家。



myDoX[®]: DORNIER CUSTOMER PORTAL

myDoX[®]: 多尼尔客户门户网站



Direct Link 4.0: the DORNIER Customer Portal myDoX[®]

Thanks to the customer portal myDoX[®] DORNIER's customers organise their production at the highest technological level. It completes and expands our personal technical DORNIER service and the weaving machine panel DORNIER ErgoWeave[®] with integrated Ethernet interface. In addition to a 24/7 online shop and the enhanced DoXWeave software for the networking of weaving machines, myDoX[®] offers also the direct 4.0 connection to experts and information from company DORNIER.



直接链接4.0: 多尼尔客户门户网站myDoX[®]

通过客户门户网站myDoX[®]多尼尔客户可以在最高技术水平上组织生产。它完成并扩展了多尼尔的个人技术服务和带有集成以太网接口的ErgoWeave[®]织机控制面板。除了24/7在线商店和用于联网织机的增强版DoXWeave软件外，myDoX[®]还提供直接4.0以连接来自多尼尔的专家和信息。

The benefits of myDoX[®]

- Online shop for original parts
- Access to user documentation
- Optimal data overview by individually definable machine groups and numbers
- Access to previous orders and current quotations
- Improved running behavior, maintenance and shorter downtimes

Log on and get started right away

This system based on HTML5 and the most modern database technology (powered by SAP HANA) does not need any plug-ins and can be comfortably operated via PC, smartphone, tablet computer or weaving machine panel.

24/7 online shop for original parts

Ordering original DORNIER parts directly and rapidly via online shop: Add the desired parts from the spare part catalogue to the cart – DORNIER ensures to deliver them promptly.

myDoX[®] 的优势

- 原厂零件在线商店
- 访问用户文档
- 通过可单独定义的机器组和数字实现最佳数据概览
- 访问以前的订单和当前报价
- 改善运行性能、维护并缩短停机时间

登录并立即开始

该系统基于HTML5和最先进的数据库技术（由SAP HANA提供支持），不需要任何插件，可以通过PC，智能手机，平板电脑或织机面板轻松操作。

24/7 原装零件在线商店

通过在线商店直接快速地订购多尼尔原装零件：将备件目录中所需的零件添加到购物车中-多尼尔确保及时交付。

THE A2 AIR-JET WEAVING MACHINE: TRIMMED FOR EFFICIENCY

A2喷气织机: 精雕细琢以提高效率

Short setup times and low maintenance

- Fast symmetrical and asymmetrical width changes
- Width changes without adaptation of fabric table length
- Low-maintenance main drive technologies
- Reproducible setting of shed closing time with DORNIER SyncroDrive®
- Universal fabric table for temple cylinder and full-width temple
- Pneumatic Shaft Lock (PSL)
- Additional keyboard for warp axis control
- Central lubrication for easy maintenance

调机时间短，维护成本低

- 快速对称和非对称幅宽调整
- 宽度变化，无需调整托布台的长度
- 低维护主驱动技术
- 使用多尼尔SyncroDrive®同步驱动可重现设置梭口开闭时间
- 用于圆柱型边撑和全幅边撑的通用织物托布台
- 气动综框锁紧系统 (PSL)
- 用于控制经轴的附加键盘
- 中央润滑，易于维护

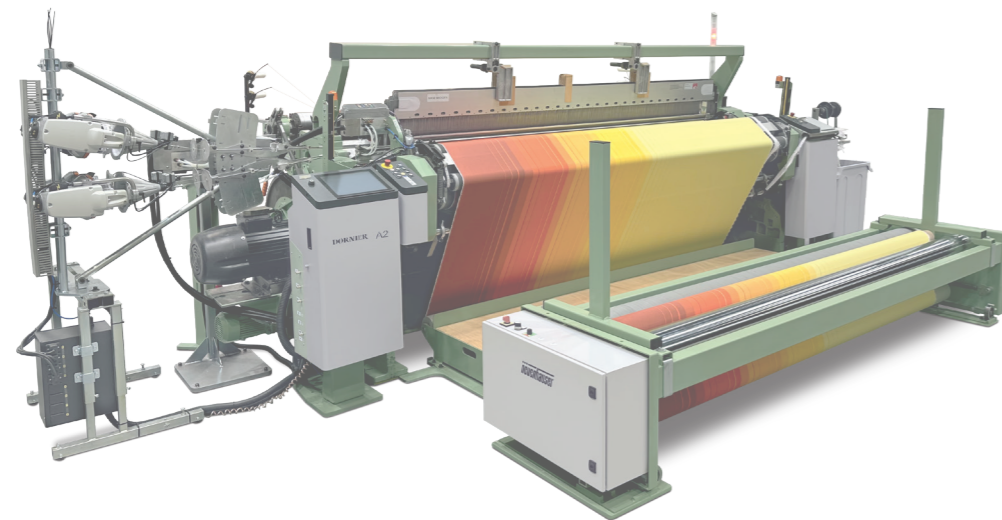

Flexible and efficient filling insertion

- Monitoring of main air supply with Electronic Pressure Monitoring (EPM) and Electronic Pressure Regulation (EPR)
- Electronic support systems to reduce air consumption
- High-performance configurations of main and pre-nozzles
- Airflow-optimized single-hole relay nozzles
- High-precision valve technology
- Automatic Filling Repair (AFR)
- Start weaving assistant (SWA) for intuitive product development

灵活高效的引纬

- 通过电子压力监测 (EPM) 和电子压力调节 (EPR) 监测
- 进口压缩空气供给
- 减少压缩空气消耗的电子支持系统
- 高性能配置主喷嘴和预喷嘴
- 气流优化的单孔辅助喷嘴
- 高精度阀门技术
- 自动纬纱修复
- 启动织造助手 (SWA) 便于直观的产品开发

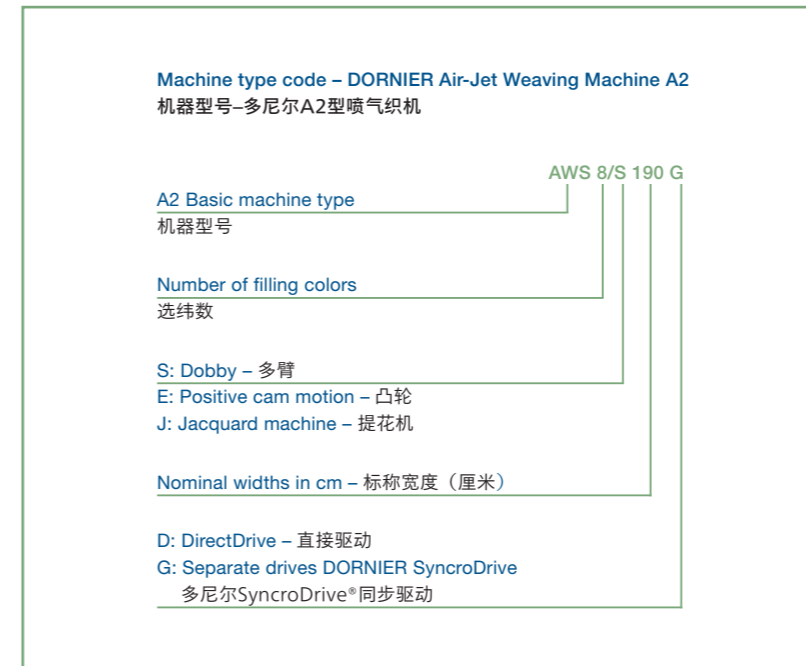

Nominal width	Machine width**	max. fabric reeded width	min. fabric reeded width***
标称宽度	机器宽度**	最大织物箱幅	最小织物箱幅***
cm / 厘米	mm / 毫米	mm / 毫米	mm / 毫米
150	4465	1480	500
170*	4665	1680	700
180	4765	1780	800
190	4865	1880	900
200*	4965	1980	1000
210*	5065	2080	1100
220	5165	2180	1200
230*	5265	2280	1300
240	5365	2380	1400
250*	5465	2480	1500
260	5565	2580	1600
280	5765	2780	1800
300*	5965	2980	2000
320	6165	3180	2200
340	6365	3380	2400
360	6565	3580	2600
380	6765	3780	2800
400	6965	3980	3000
430	7265	4280	3300
460*	7565	4580	3600
540	8365	5380	4400

Other weaving machine nominal widths and special versions on request

Overall depth
with 800 mm warp beam \varnothing 1,868 mm
with 1,000 mm warp beam \varnothing 2,160 mm

* On special request
** width valid for dobbies with 6 colors
***further width reductions on request

For precise measurements of each type of machine outlined, please contact DORNIER. Subject to change

可根据用户要求更改幅宽

总体深度 (毫米)
经轴边盘直径 800 毫米 \varnothing 1,868 毫米
经轴边盘直径 1,000 毫米 \varnothing 2,160 毫米

* 根据特殊要求
** 宽度适用于 6 色选纬的多臂开口织机
***可根据要求进一步减少宽度

各迹象织机的详细外形尺寸，请联系多尼尔。多尼尔保留修改权



Lindauer DORNIER GmbH

Rickenbacher Str. 119
88131 Lindau, Germany
Telephone +49 8382 7030

American DORNIER Machinery Corp.

P.O. Box 668865
Charlotte, N.C. 28266, USA
Telephone +1 704 697 3310

**DORNIER Machinery India
Private Limited**

201-A, Sangeet Plaza
Marol Maroshi Road
Andheri (East)
Mumbai 400 059, India
Telephone +91 22 292 506 74

DORNIER Makina Ltd. Sti.

Oruç Reis Mahallesi
Giyimkent Sitesi 6. Sokak B64 No. 38-40
34235 Esenler/Istanbul, Turkey
Telephone +90 212 4266 998

DORNIER Machinery (Shanghai) Co. Ltd.

WaiGaoQiao Tax Free Zone
299 FuTeZhong Road
Area B G/F Block 45
Shanghai 200131, China
Telephone +86 21 504 628 38

www.lindauerdornier.com
sales.sm@lindauerdornier.com